

## 3.5-MHz High Efficiency Step-Up Converter

 Check for Samples: [TPS61240](#), [TPS61241](#)

### FEATURES

- Efficiency > 90% at Nominal Operating Conditions
- Total DC Output Voltage Accuracy 5.0V±2%
- Typical 30  $\mu$ A Quiescent Current
- *Best in Class* Line and Load Transient
- Wide  $V_{IN}$  Range From 2.3V to 5.5V
- Output current up to 450mA
- Automatic PFM/PWM Mode transition
- Low Ripple Power Save Mode for Improved Efficiency at Light Loads
- Internal Softstart, 250 $\mu$ s typical Start-Up time
- 3.5MHz Typical Operating Frequency
- Load Disconnect During Shutdown
- Current Overload and Thermal Shutdown Protection
- Three Surface-Mount External Components Required (One MLCC Inductor, Two Ceramic Capacitors)
- Total Solution Size <13 mm<sup>2</sup>
- Available in a 6-pin WCSP and 2×2-SON Package

### APPLICATIONS

- USB-OTG Applications
- Portable HDMI Applications
- Cell Phones, Smart-Phones
- PDAs, Pocket PCs
- Portable Media Players
- Digital Cameras

### DESCRIPTION

The TPS6124x device is a high efficient synchronous step up DC-DC converter optimized for products powered by either a three-cell alkaline, NiCd or NiMH, or one-cell Li-Ion or Li-Polymer battery. The TPS6124x supports output currents up to 450mA. The TPS61240 has an input valley current limit of 500mA, and the TPS61241 has an input valley current of 600mA.

With an input voltage range of 2.3V to 5.5V the device supports batteries with extended voltage range and are ideal to power portable applications like mobile phones and other portable equipment. The TPS6124x boost converter is based on a quasi-constant on-time valley current mode control scheme.

The TPS6124x presents a high impedance at the  $V_{OUT}$  pin when shut down. This allows for use in applications that require the regulated output bus to be driven by another supply while the TPS6124x is shut down.

During light loads the device will automatically pulse skip allowing maximum efficiency at lowest quiescent currents. In the shutdown mode, the current consumption is reduced to less than 1 $\mu$ A.

TPS6124x allows the use of small inductors and capacitors to achieve a small solution size. During shutdown, the load is completely disconnected from the battery. The TPS6124x is available in a 6-pin WCSP and 2×2 SON package.

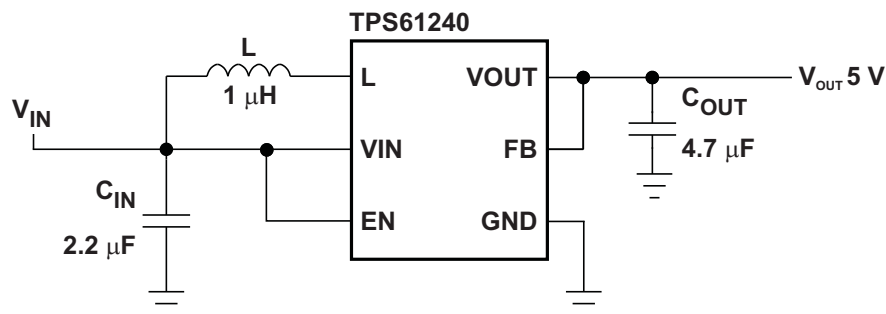

Please be aware that an important notice concerning availability, standard warranty, and use in critical applications of Texas Instruments semiconductor products and disclaimers thereto appears at the end of this data sheet.

# TPS61240, TPS61241

SLVS806B – APRIL 2009 – REVISED FEBRUARY 2012

[www.ti.com](http://www.ti.com)

These devices have limited built-in ESD protection. The leads should be shorted together or the device placed in conductive foam during storage or handling to prevent electrostatic damage to the MOS gates.

## ORDERING INFORMATION

PART NUMBER <sup>(1)</sup>	OUTPUT VOLTAGE	DEVICE SPECIFIC FEATURES	PACKAGE	ORDERING	PACKAGE MARKING
TPS61240	5V		6-WCSP	TPS61240YFF	GM
			6-QFN	TPS61240DRV	OCJ
TPS61241		Supports 5V, up to 300mA loading down to 3.2V input voltage	6-WCSP	TPS61241YFF	NF
TPS61242 <sup>(2)</sup>		Optimized to drive an inductive load	6-WCSP	TPS61242YFF	RY

(1) The YFF package is available in tape on reel. Add R suffix (TPS61240YFFR) to order quantities of 3000 parts per reel. Add a T suffix (TPS61240YFFT) to order quantities of 250 parts.

(2) Product preview. [Contact TI factory for more information](#)

## ABSOLUTE MAXIMUM RATINGS

over operating free-air temperature range (unless otherwise noted)<sup>(1) (2)</sup>

		VALUE	UNIT
V <sub>I</sub>	Input voltage range on V <sub>IN</sub> , L, EN	-0.3 to 7	V
	Voltage on V <sub>OUT</sub>	-2.0 to 7	V
	Voltage on FB	-2.0 to 14	V
	Peak output current	Internally limited	A
ESD rating <sup>(3)</sup>	Human Body Model	4000	V
	CDM Charged Device Model	500	V
	Machine Model	200	V
T <sub>J</sub>	Maximum operating junction temperature	-40 to 125	°C
T <sub>stg</sub>	Storage temperature range	-65 to 150	°C

(1) Stresses beyond those listed under *absolute maximum ratings* may cause permanent damage to the device. These are stress ratings only and functional operation of the device at these or any other conditions beyond those indicated under *recommended operating conditions* is not implied. Exposure to absolute-maximum-rated conditions for extended periods may affect device reliability.

(2) All voltage values are with respect to network ground terminal.

(3) The human body model is a 100pF capacitor discharged through a 1.5 kΩ resistor into each pin. The machine model is a 200pF capacitor discharged directly into each pin.

## DISSIPATION RATINGS TABLE<sup>(1)</sup>

PACKAGE	R <sub>θJA</sub>	POWER RATING T <sub>A</sub> ≤ 25°C	DERATING FACTOR ABOVE T <sub>A</sub> = 25°C
DRV	76°C/W	1300mW	13mW/°C
YFF	125°C/W	800mW	8mW/°C

(1) Maximum power dissipation is a function of T<sub>J(max)</sub>, θ<sub>JA</sub> and T<sub>A</sub>. The maximum allowable power dissipation at any allowable ambient temperature is P<sub>D</sub> = [T<sub>J(max)</sub> - T<sub>A</sub>] / θ<sub>JA</sub>.

(2) This thermal data is measured with high-K board (4 layer board according to JESD51-7 JEDEC standard).

**RECOMMENDED OPERATING CONDITIONS**

		MIN	NOM	MAX	UNIT
V <sub>IN</sub>	Input voltage range	2.3		5.5	V
L	Inductance	0.4	1	1.5	μH
C <sub>O</sub>	Output capacitance	TPS61240 TPS61241	1	20	μF
		TPS61242	0.8	10	μF
T <sub>A</sub>	Operating ambient temperature	–40		85	°C
T <sub>J</sub>	Operating junction temperature	–40		125	°C

**ELECTRICAL CHARACTERISTICS**

Over full operating ambient temperature range, typical values are at T<sub>A</sub> = 25°C. Unless otherwise noted, specifications apply for condition V<sub>IN</sub> = EN = 3.6V. External components C<sub>IN</sub> = 2.2μF, C<sub>OUT</sub> = 4.7μF 0603, L = 1μH, refer to PARAMETER MEASUREMENT INFORMATION.

PARAMETER		TEST CONDITIONS	MIN	TYP	MAX	UNIT
<b>DC/DC STAGE</b>						
V <sub>IN</sub>	Input voltage range		2.3		5.5	V
V <sub>OUT</sub>	Fixed output voltage range	2.3 V ≤ V <sub>IN</sub> ≤ 5.5 V, 0 mA ≤ I <sub>OUT</sub> ≤ 200 mA	4.9	5.0	5.1	V
V <sub>O_Ripple</sub>	Ripple voltage, PWM mode	I <sub>LOAD</sub> = 150 mA			20	mVpp
I <sub>SW</sub>	Output current	V <sub>IN</sub> 2.3 V to 5.5 V	200			mA
	Switch valley current limit	V <sub>OUT</sub> = V <sub>GS</sub> = 5.0 V (TPS61240)	500	600		mA
		V <sub>OUT</sub> = V <sub>GS</sub> = 5.0 V (TPS61241, TPS61242)	600	700		mA
	Short circuit current	V <sub>OUT</sub> = V <sub>GS</sub> = 5.0 V	200	350		mApk
	High side MOSFET on-resistance <sup>(1)</sup>	V <sub>IN</sub> = V <sub>GS</sub> = 5.0V, T <sub>A</sub> = 25°C <sup>(1)</sup>		290		mΩ
	Low Side MOSFET on-resistance <sup>(1)</sup>	V <sub>IN</sub> = V <sub>GS</sub> = 5.0 V, T <sub>A</sub> = 25°C <sup>(1)</sup>		250		mΩ
	Operating quiescent current	I <sub>OUT</sub> = 0 mA, Power save mode		30	40	μA
	Shutdown current	EN = GND			1.5	μA
	Reverse leakage current V <sub>OUT</sub>	EN = 0, V <sub>OUT</sub> = 5 V			2.5	μA
	Leakage current from battery to V <sub>OUT</sub>	EN = GND			2.5	μA
	Line transient response	V <sub>IN</sub> 600 mVp-p AC square wave, 200Hz, 12.5% DC at 50/200mA load		±25	±50	mVpk
Load transient response	0–50 mA, 50–0 mA V <sub>IN</sub> = 3.6V T <sub>Rise</sub> = T <sub>Fall</sub> = 0.1μs		50		mVpk	
	50–200 mA, 200–50 mA, V <sub>IN</sub> = 3.6 V, T <sub>Rise</sub> = T <sub>Fall</sub> = 0.1μs		150			
I <sub>IN</sub>	Input bias current, EN	EN = GND or V <sub>IN</sub>	0.01	1.0		μA
V <sub>UVLO</sub>	Undervoltage lockout threshold	Falling		2.0	2.1	V
		Rising		2.1	2.2	V
<b>CONTROL STAGE</b>						
V <sub>IH</sub>	High level input voltage, EN	2.3 V ≤ V <sub>IN</sub> ≤ 5.5 V			1.0	V
V <sub>IL</sub>	Low level input voltage, EN	2.3 V ≤ V <sub>IN</sub> ≤ 5.5 V	0.4			V
OVC	Input over-voltage threshold	Falling		5.9		V
		Rising		6.0		
t <sub>Start</sub>	Start-up time	Time from active EN to start switching, no-load until V <sub>OUT</sub> is stable 5V			300	μs
<b>DC/DC STAGE</b>						
Freq		See <a href="#">Figure 7</a> (Frequency Dependency vs I <sub>OUT</sub> )		3.5		MHz
T <sub>SD</sub>	Thermal shutdown	Increasing junction temperature		140		°C
	Thermal shutdown hysteresis	Decreasing junction temperature		20		°C

(1) DRV package has an increased R<sub>DSon</sub> of about 40mΩ due to bond wire resistance.

## PIN ASSIGNMENTS

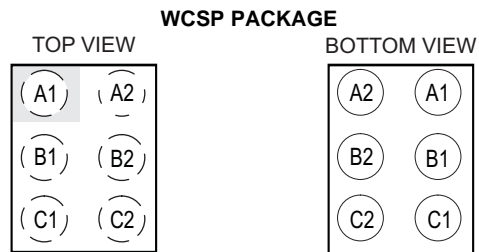

**QFN PACKAGE (TOP VIEW)**

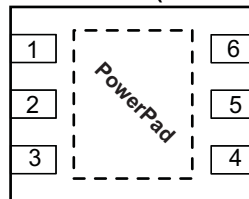

## PIN FUNCTIONS

PIN NO.		PIN NAME	FUNCTION	REMARKS
QFN	WCSP			
2	B2	$V_{OUT}$	Output	Connected to load
6	A1	$V_{IN}$	Supply voltage	Supply from battery
5	B1	L	Boost and rectifying switch input	Inductor connection to FETs
4	C1	EN	Enable	Positive polarity. Low = IC shutdown.
3	C2	FB	Feedback input	Feedback for regulation.
1	A2	GND	Ground	Power ground and IC ground

**FUNCTIONAL BLOCK DIAGRAM**

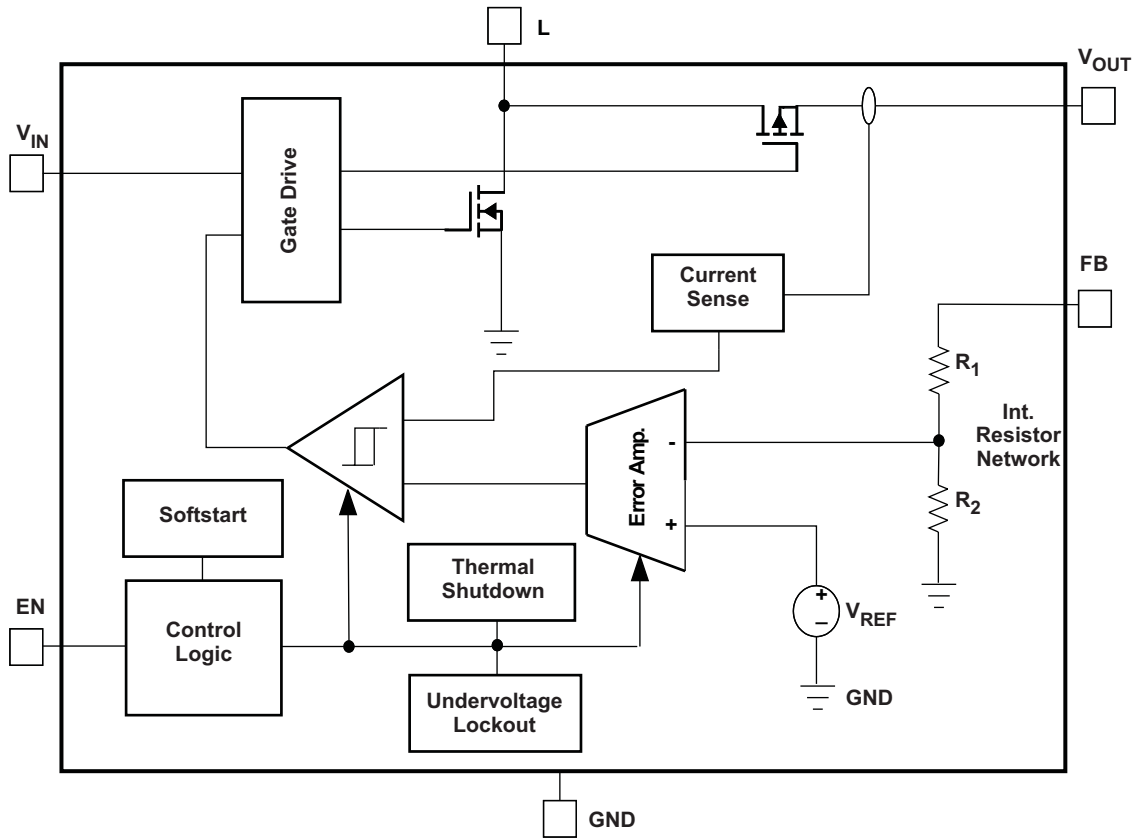

**PARAMETER MEASUREMENT INFORMATION**

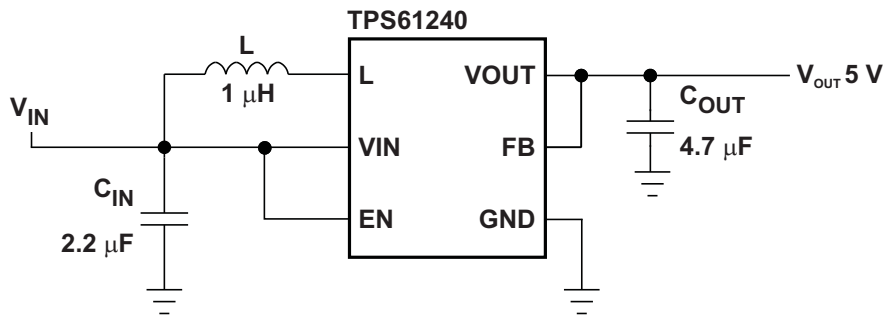

**List of Components**

COMPONENT REFERENCE	PART NUMBER	MANUFACTURER	VALUE
C <sub>IN</sub>	JMK105BJ225MV	Taiyo Yuden	2.2 μF, X5R, 6.3 V, 0402
C <sub>OUT</sub>	JDK105BJ475MV	Taiyo Yuden	4.7 μF, X5R, 6.3 V, 0402
L	MDT2012-CH1R0AN	TOKO	1.0 μH, 900mA, 0805

TYPICAL CHARACTERISTICS

Table of Graphs

Table 1.

		Figure
Maximum Output Current	vs Input Voltage	1
Efficiency	vs Output Current, $V_{out} = 5V$ , $V_{in} = [2.3V; 3.0V; 3.6V; 4.2V]$	2
	vs Input Voltage, $V_{out} = 5V$ , $I_{out} = [100\mu A; 1mA; 10mA; 100mA; 200mA]$	3
Input Current	at No Output Load, Device Disabled	4
Output Voltage	vs Output Current, $V_{out} = 5V$ , $V_{in} = [2.3V; 3.0V; 3.6V; 4.2V]$	5
	vs Input Voltage	6
Frequency	vs Output Load, $V_{out} = 5V$ , $V_{in} = [3.0V; 4.0V; 5.0V]$	7
Waveforms	Output Voltage Ripple, PFM Mode, $I_{out} = 10mA$	8
	Output Voltage Ripple, PWM Mode, $I_{out} = 150mA$	9
	Load Transient Response, $V_{in} = 3.6V$ , 0 - 50mA	10
	Load Transient Response, $V_{in} = 3.6V$ , 50 - 200mA	11
	Line Transient Response, $V_{in} = 3.6V - 4.2V$ , $I_{out} = 50mA$	12
	Line Transient Response, $V_{in} = 3.6V - 4.2V$ , $I_{out} = 200mA$	13
	Startup after Enable, $V_{in} = 3.6V$ , $V_{out} = 5V$ , Load = 5K $\Omega$	14
	Startup after Enable, $V_{in} = 3.6V$ , $V_{out} = 5V$ , Load = 16.5 $\Omega$	15
	Startup and Shutdown, $V_{in} = 3.6V$ , $V_{out} = 5V$ , Load = 16.5 $\Omega$	16

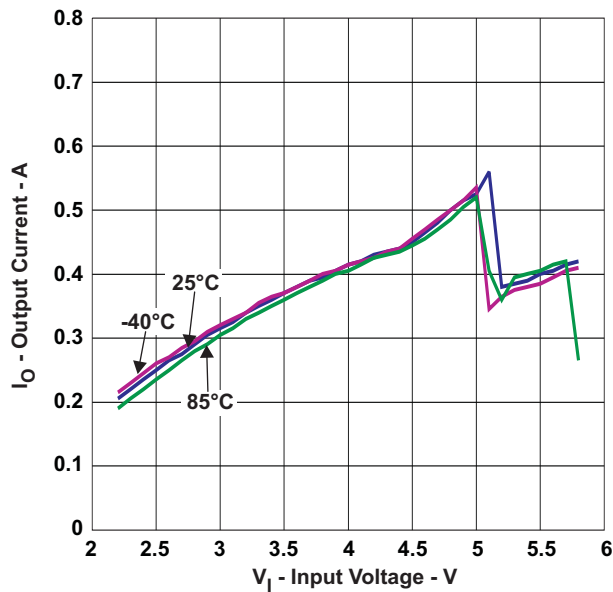

Figure 1. Maximum Output Current vs Input Voltage

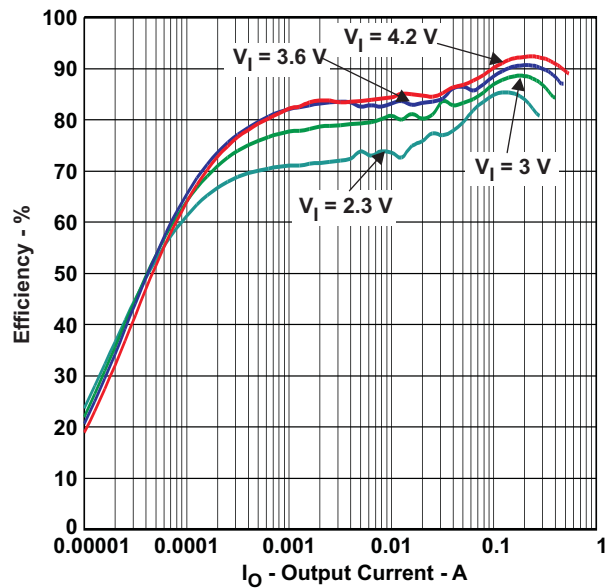

Figure 2. Efficiency vs Output Current

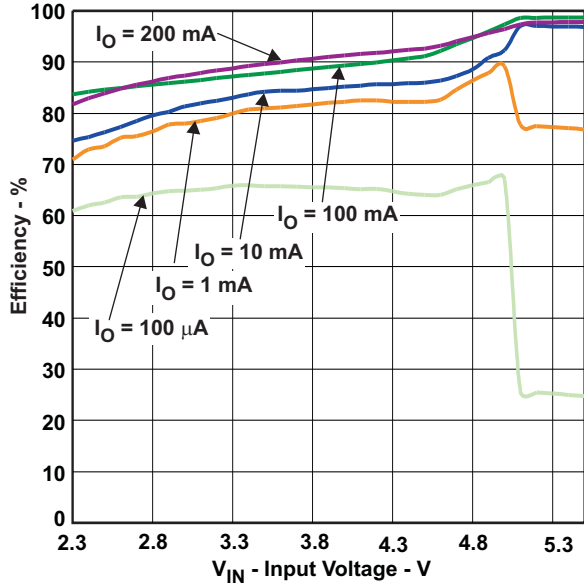

Figure 3. Efficiency vs Input Voltage

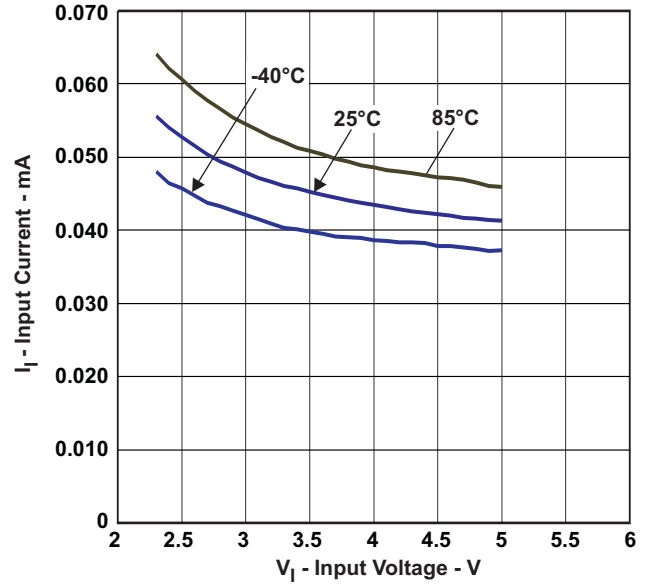

Figure 4. Input at No Output Load

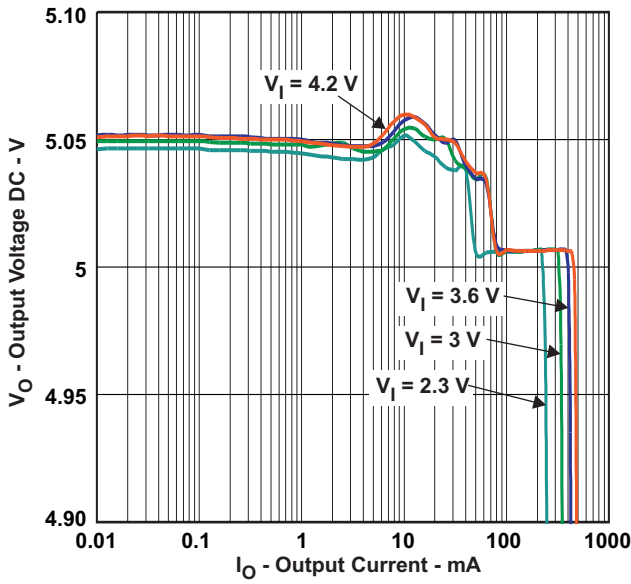

Figure 5. Output Voltage vs Output Current

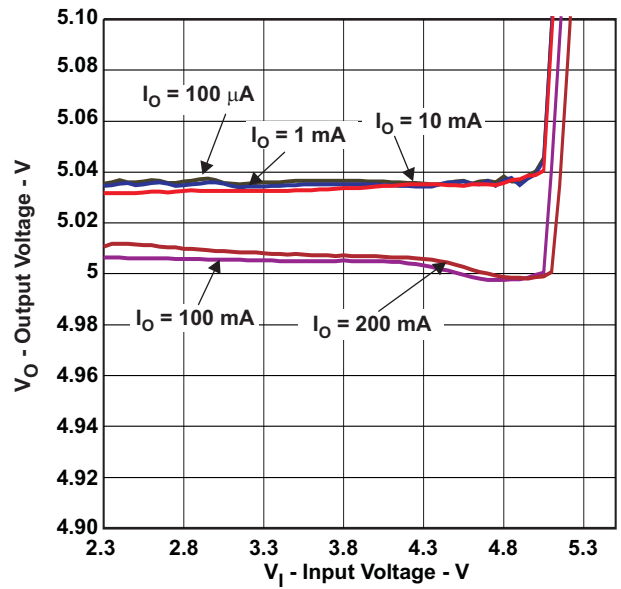

Figure 6. Output Voltage vs Input Voltage

TPS61240, TPS61241

SLVS806B – APRIL 2009 – REVISED FEBRUARY 2012

www.ti.com

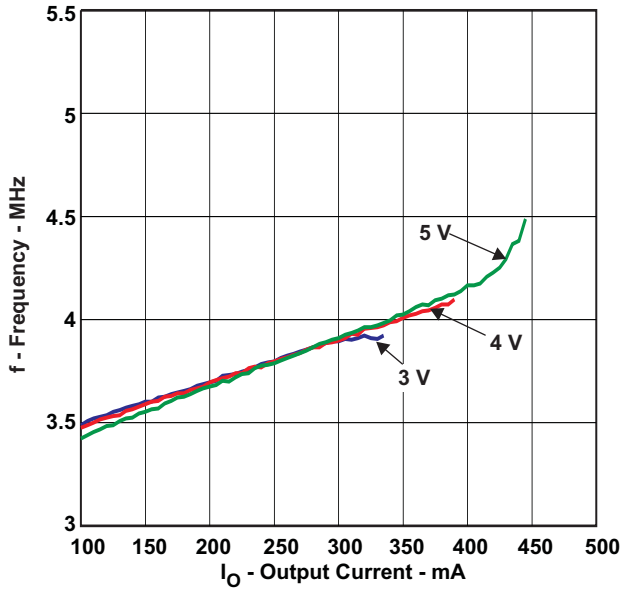

Figure 7. Frequency vs Output Load

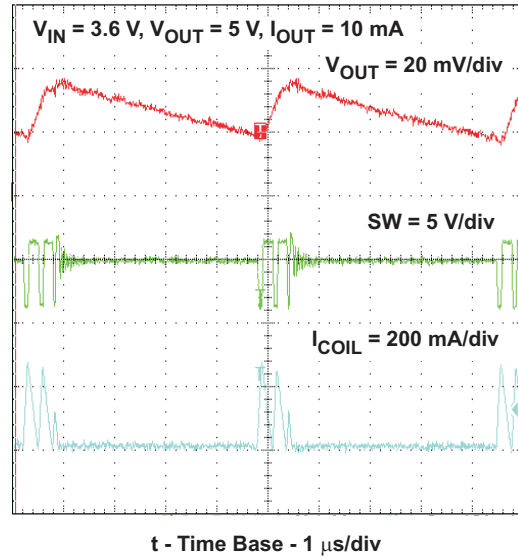

Figure 8. Output Voltage Ripple – PFM Mode

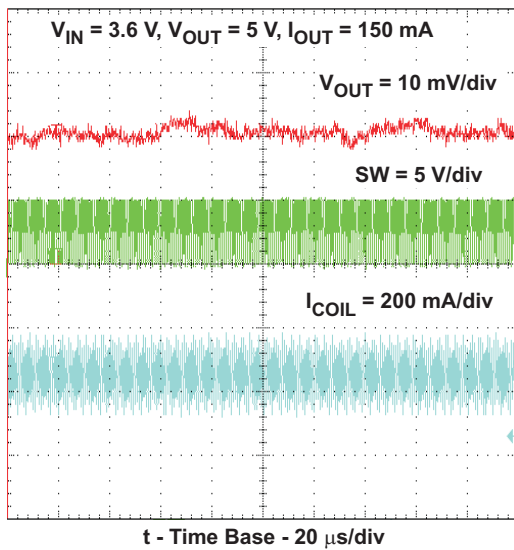

Figure 9. Output Voltage Ripple – PWM Mode

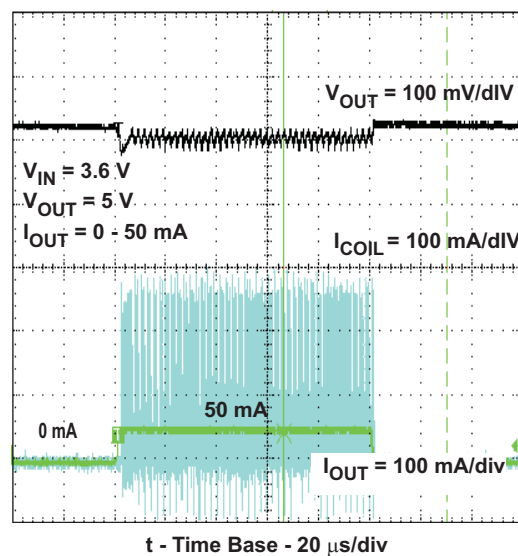

Figure 10. Load Transient Response 0mA–50mA and 50mA–0mA

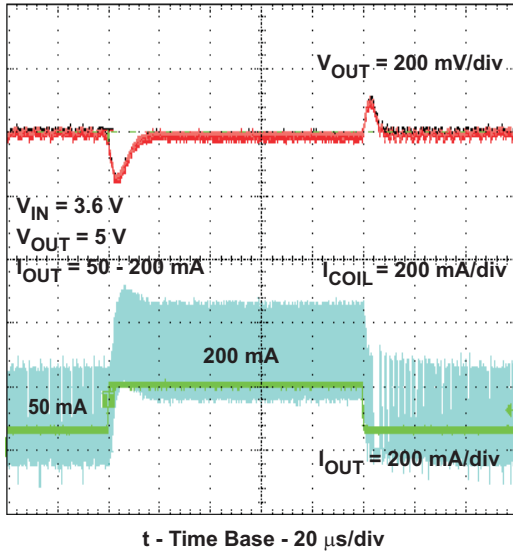

Figure 11. Load Transient Response 0mA–200mA and 200mA–0mA

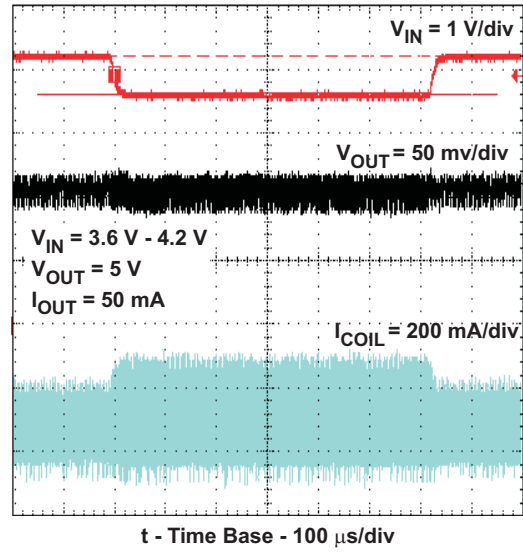

Figure 12. Line Transient Response 3.6V–4.2V at 50mA Load

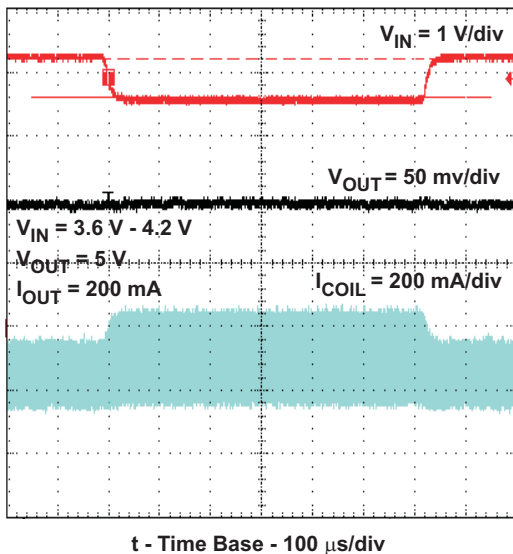

Figure 13. Line Transient Response 3.6V–4.2V at 200mA Load

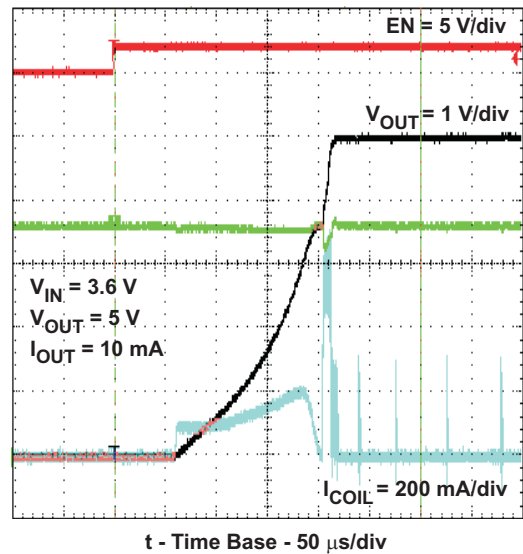

Figure 14. Startup After Enable – No Load

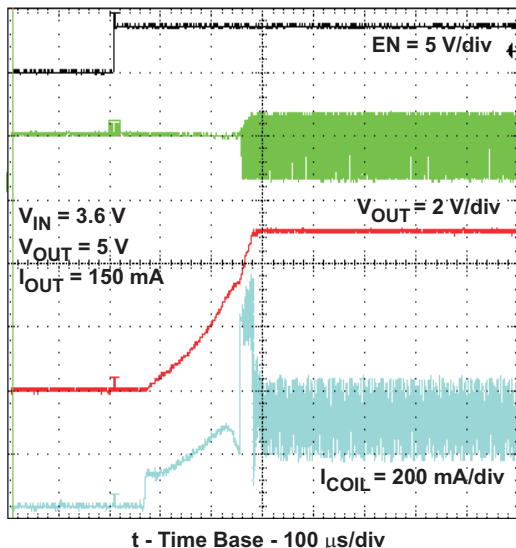

Figure 15. Startup After Enable – With Load

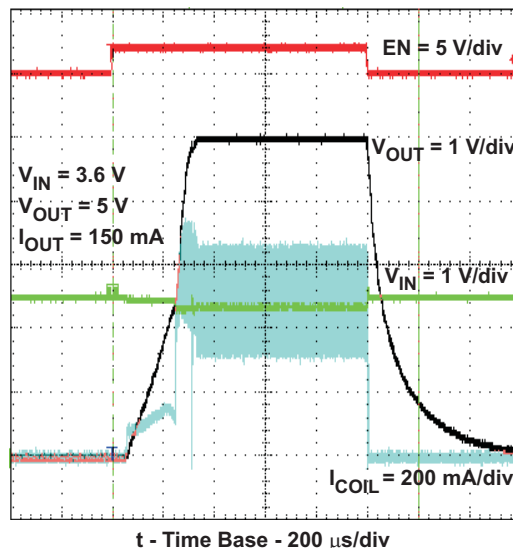

Figure 16. Startup and Shutdown

## DETAILED DESCRIPTION

### OPERATION

The TPS6124x Boost Converter operates with typically 3.5MHz fixed frequency pulse width modulation (PWM) at moderate to heavy load currents. At light load currents the converter will automatically enter Power Save Mode and operates then in PFM (Pulse Frequency Modulation) mode. During PWM operation the converter uses a unique fast response quasi-constant on-time valley current mode controller scheme which allows “Best in Class” line and load regulation allowing the use of small ceramic input and output capacitors.

Based on the  $V_{IN}/V_{OUT}$  ratio, a simple circuit predicts the required on-time. At the beginning of the switching cycle, the low-side N-MOS switch is turned-on and the inductor current ramps up to a defined peak current. In the second phase, once the peak current is reached, the current comparator trips, the on-timer is reset turning off the switch, and the current through the inductor then decays to an internally set valley current limit. Once this occurs, the on-timer is set to turn the boost switch back on again and the cycle is repeated.

### CURRENT LIMIT OPERATION

The current limit circuit employs a valley current sensing scheme. Current limit detection occurs during the off time through sensing of the voltage drop across the synchronous rectifier.

The output voltage is reduced as the power stage of the device operates in a constant current mode. The maximum continuous output current ( $I_{OUT(CL)}$ ), before entering current limit operation, can be defined by [Equation 1](#) as shown.

$$I_{OUT(CL)} = (1 - D) \times (I_{VALLEY} + \frac{1}{2} \Delta I_L) \quad \text{with } \Delta I_L = \frac{V_{IN}}{L} \times \frac{D}{f} \quad \text{and } D \approx \frac{V_{OUT} - V_{IN}}{V_{OUT}} \quad (1)$$

[Figure 17](#) illustrates the inductor and rectifier current waveforms during current limit operation. The output current,  $I_{OUT}$ , is the average of the rectifier ripple current waveform. When the load current is increased such that the lower peak is above the current limit threshold, the off time is lengthened to allow the current to decrease to this threshold before the next on-time begins (so called frequency fold-back mechanism).

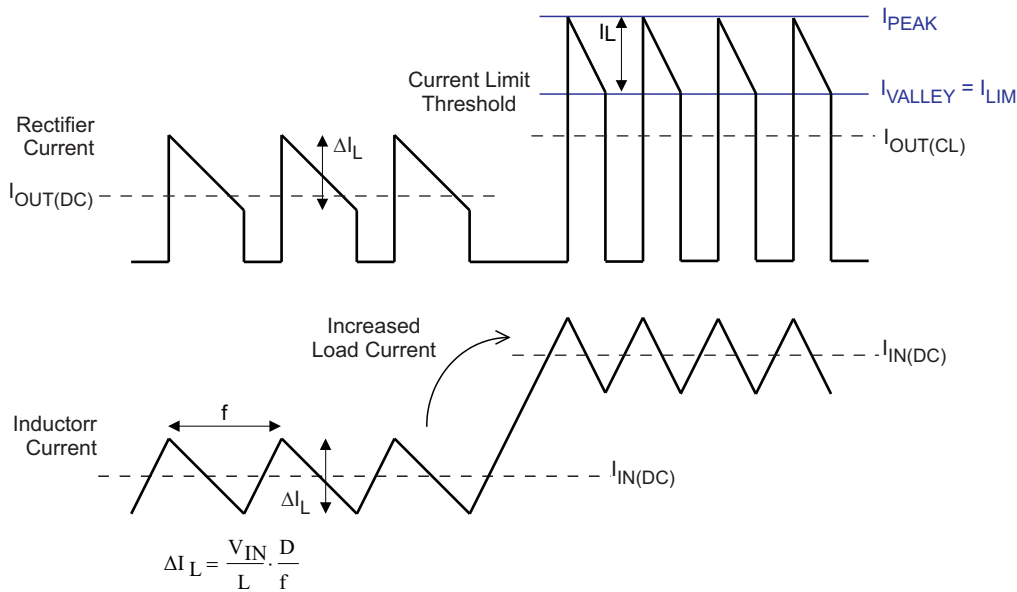
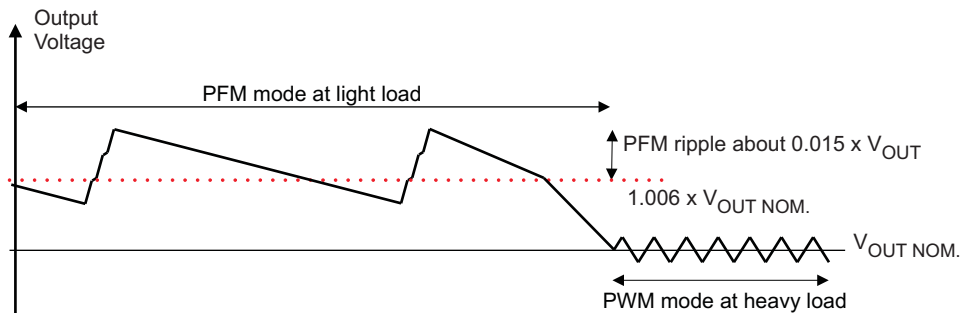

Figure 17. Inductor/Rectifier Currents in Current Limit Operation

## POWER-SAVE MODE

The TPS6124x family of devices integrates a power save mode to improve efficiency at light load. In power save mode the converter only operates when the output voltage trips below a set threshold voltage. It ramps up the output voltage with several pulses and goes into power save mode once the output voltage exceeds the set threshold voltage.



The PFM mode is left and PWM mode entered in case the output current can not longer be supported in PFM mode.

## UNDER-VOLTAGE LOCKOUT

The under voltage lockout circuit prevents the device from malfunctioning at low input voltages and from excessive discharge of the battery. It disables the output stage of the converter once the falling  $V_{IN}$  trips the under-voltage lockout threshold  $V_{UVLO}$ . The under-voltage lockout threshold  $V_{UVLO}$  for falling  $V_{IN}$  is typically 2.0V. The device starts operation once the rising  $V_{IN}$  trips under-voltage lockout threshold  $V_{UVLO}$  again at typ. 2.1V.

## INPUT OVER-VOLTAGE PROTECTION

In the event of an overvoltage condition appearing on the input rail, the output voltage will also experience the overvoltage due to being in dropout condition. A input overvoltage protection feature has been implemented into the TPS6124x which has an input overvoltage threshold of 6.0V. Once this level is triggered, the device will go into a shutdown mode to protect itself. If the voltage drops to 5.9V or below, the device will startup once more into normal operation.

## TPS61240, TPS61241

SLVS806B – APRIL 2009 – REVISED FEBRUARY 2012

www.ti.com

### ENABLE

The device is enabled setting EN pin to high. At first, the internal reference is activated and the internal analog circuits are settled. Afterwards, the soft start is activated and the output voltage is ramped up. The output voltage reaches its nominal value in typically 250  $\mu$ s after the device has been enabled.

The EN input can be used to control power sequencing in a system with various DC/DC converters. The EN pin can be connected to the output of another converter, to drive the EN pin high and getting a sequencing of supply rails. With EN = GND, the device enters shutdown mode.

### SOFT START

The TPS6124x has an internal soft start circuit that controls the ramp up of the output voltage. The output voltage reaches its nominal value within  $t_{\text{Start}}$  of typically 250  $\mu$ s after EN pin has been pulled to high level. The output voltage ramps up from 5% to its nominal value within  $t_{\text{RAMP}}$  of typ. 300  $\mu$ s.

This limits the inrush current in the converter during start up and prevents possible input voltage drops when a battery or high impedance power source is used.

During soft start, the switch current limit is reduced to 300mA until the output voltage reaches  $V_{\text{IN}}$ . Once the output voltage trips this threshold, the device operates with its nominal current limit  $I_{\text{LIMF}}$ .

### LOAD DISCONNECT

Load disconnect electrically removes the output from the input of the power supply when the supply is disabled. This is especially important during shutdown. In shutdown of a boost converter, the load is still connected to the input through the inductor and catch diode. Since the input voltage is still connected to the output, a small current continues to flow, even when the supply is disabled. Even small leakage currents significantly reduce battery life during extended periods of off time.

The benefit of this implemented feature for the system design engineer is that the battery is not depleted during shutdown of the converter. No additional components must be added to the design to make sure that the battery is disconnected from the output of the converter.

### THERMAL SHUTDOWN

As soon as the junction temperature,  $T_{\text{J}}$ , exceeds 140°C (typical) the device goes into thermal shutdown. In this mode, the High Side and Low Side MOSFETs are turned-off. When the junction temperature falls below the thermal shutdown hysteresis, the device continues operation.

APPLICATION INFORMATION

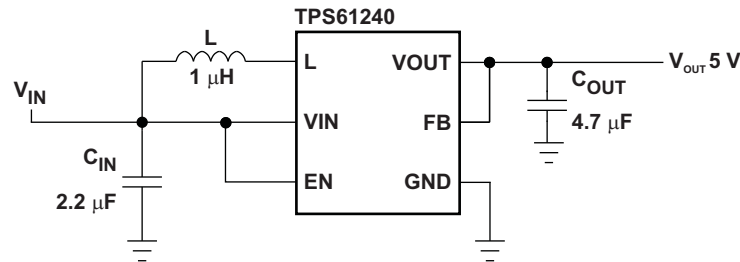

Figure 18. TPS61240 Fixed 5.0V for HDMI / USB-OTG Applications

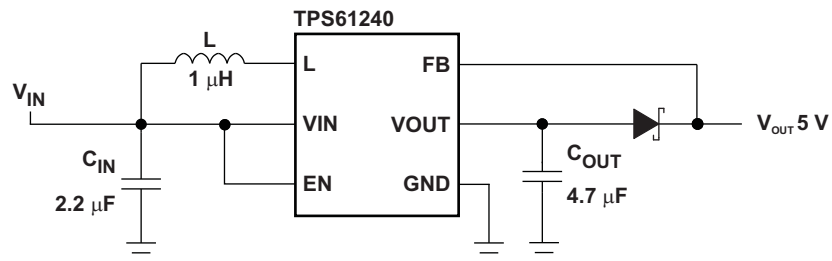

Figure 19. TPS61240 Fixed 5.0V With Schottky Diode for Output Overvoltage Protection

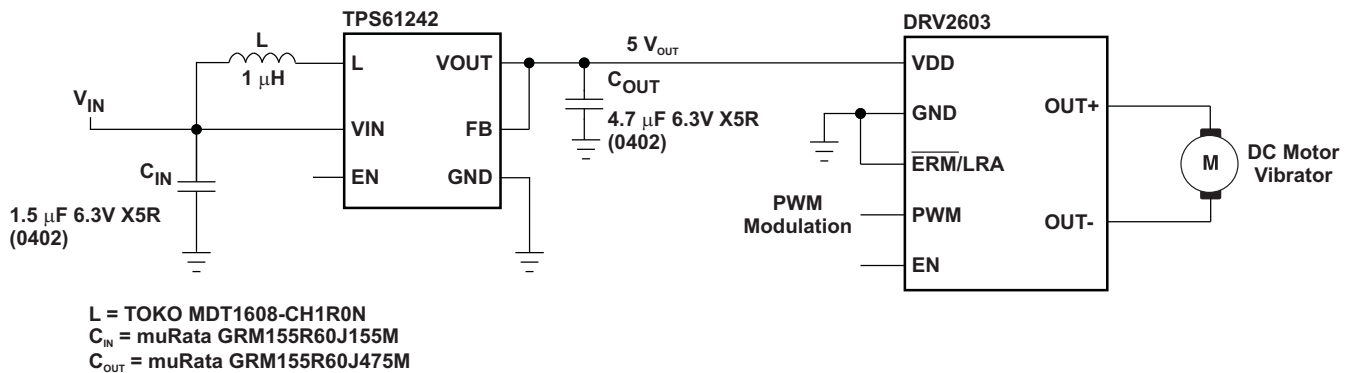

Figure 20. DRV2603 + TPS61242 Haptic Driver Solution featuring PWM Modulation Control

## DESIGN PROCEDURE

### PROGRAMMING THE OUTPUT VOLTAGE

The output voltage is set by a resistor divider internally. The FB pin is used to sense the output voltage. To configure the output properly, the FB pin needs to be connected directly as shown in [Figure 18](#) and [Figure 19](#).

### INDUCTOR SELECTION

To make sure that the TPS6124x devices can operate, an inductor must be connected between pin  $V_{IN}$  and pin L. A boost converter normally requires two main passive components for storing energy during the conversion. A boost inductor and a storage capacitor at the output are required. To select the boost inductor, it is recommended to keep the possible peak inductor current below the current limit threshold of the power switch in the chosen configuration. The highest peak current through the inductor and the switch depends on the output load, the input ( $V_{IN}$ ), and the output voltage ( $V_{OUT}$ ). Estimation of the maximum average inductor current can be done using [Equation 2](#).

$$I_{L\_MAX} \approx I_{OUT} \times \frac{V_{OUT}}{\eta \times V_{IN}} \quad (2)$$

For example, for an output current of 200mA at 5.0V  $V_{OUT}$ , at least 540mA of average current flows through the inductor at a minimum input voltage of 2.3V.

The second parameter for choosing the inductor is the desired current ripple in the inductor. Normally, it is advisable to work with a ripple of less than 20% of the average inductor current. A smaller ripple reduces the magnetic hysteresis losses in the inductor, as well as output voltage ripple and EMI. But in the same way, regulation time at load changes rises. In addition, a larger inductor increases the total system size and cost. With these parameters, it is possible to calculate the value of the minimum inductance by using [Equation 3](#).

$$L_{MIN} \approx \frac{V_{IN} \times (V_{OUT} - V_{IN})}{\Delta I_L \times f \times V_{OUT}} \quad (3)$$

Parameter  $f$  is the switching frequency and  $\Delta I_L$  is the ripple current in the inductor, i.e.,  $20\% \times I_L$ . In this example, the desired inductor has the value of 1.7  $\mu\text{H}$ . With this calculated value and the calculated currents, it is possible to choose a suitable inductor. In typical applications a 1.0  $\mu\text{H}$  inductance is recommended. The device has been optimized to operate with inductance values between 1.0  $\mu\text{H}$  and 2.2  $\mu\text{H}$ . It is recommended that inductance values of at least 1.0  $\mu\text{H}$  is used, even if [Equation 3](#) yields something lower. Care has to be taken that load transients and losses in the circuit can lead to higher currents as estimated in Equation 3. Also, the losses in the inductor caused by magnetic hysteresis losses and copper losses are a major parameter for total circuit efficiency.

With the chosen inductance value, the peak current for the inductor in steady state operation can be calculated. [Equation 4](#) shows how to calculate the peak current  $I$ .

$$I_{L(\text{peak})} = \frac{V_{IN} \times D}{2 \times f \times L} + \frac{I_{OUT}}{(1 - D) \times \eta} \quad \text{with } D = \frac{V_{OUT} - V_{IN}}{V_{OUT}} \quad (4)$$

This would be the critical value for the current rating for selecting the inductor. It also needs to be taken into account that load transients and error conditions may cause higher inductor currents.

**Table 2. Table 1. List of Inductors**

Manufacturer	Series	Dimensions
TOKO	MDT2012-CH1R0AN	2.0 x 1.2 x 1.0 max. height
	MDT1608-CH1R0N	1.6 x 0.8 x 0.95 max. height
Hitachi Metals	KSLI-201210AG-1R0	2.0 x 1.2 x 1.0 max. height
	KSLI-201610AG-1R0	2.0 x 1.6 x 1.0 max. height
muRata	LQM21PN1R0MC0	2.0 x 1.2 x 0.55 max. height
FDK	MIPS2012D1R0-X2	2.0 x 1.2 x 1.0 max. height

## INPUT CAPACITOR

At least 2.2µF input capacitor is recommended to improve transient behavior of the regulator and EMI behavior of the total power supply circuit. It is recommended to place a ceramic capacitor as close as possible to the VIN and GND pins

## OUTPUT CAPACITOR

For the output capacitor, it is recommended to use small ceramic capacitors placed as close as possible to the V<sub>OUT</sub> and GND pins of the IC. If, for any reason, the application requires the use of large capacitors which can not be placed close to the IC, using a smaller ceramic capacitor in parallel to the large one is recommended. This small capacitor should be placed as close as possible to the V<sub>OUT</sub> and GND pins of the IC. To get an estimate of the recommended minimum output capacitance, Equation 5 can be used.

$$C_{\min} = \frac{I_{\text{OUT}} \times (V_{\text{OUT}} - V_{\text{IN}})}{f \times \Delta V \times V_{\text{OUT}}} \quad (5)$$

Parameter f is the switching frequency and ΔV is the maximum allowed ripple.

With a chosen ripple voltage of 10 mV, a minimum effective capacitance of 2.7 µF is needed. The total ripple is larger due to the ESR of the output capacitor. This additional component of the ripple can be calculated using  $\Delta V_{\text{ESR}} = I_{\text{OUT}} \times R_{\text{ESR}}$

A capacitor with a value in the range of the calculated minimum should be used. This is required to maintain control loop stability. There are no additional requirements regarding minimum ESR. There is no upper limit for the output capacitance value. Larger capacitors cause lower output voltage ripple as well as lower output voltage drop during load transients.

Note that ceramic capacitors have a DC Bias effect, which will have a strong influence on the final effective capacitance needed. Therefore the right capacitor value has to be chosen carefully. Package size and voltage rating in combination with material are responsible for differences between the rated capacitor value and the effective capacitance.

## CHECKING LOOP STABILITY

The first step of circuit and stability evaluation is to look from a steady-state perspective at the following signals:

- Switching node, SW
- Inductor current, I<sub>L</sub>
- Output ripple voltage, V<sub>O(AC)</sub>

These are the basic signals that need to be measured when evaluating a switching converter. When the switching waveform shows large duty cycle jitter or the output voltage or inductor current shows oscillations, the regulation loop may be unstable. This is often a result of board layout and/or L-C combination.

As a next step in the evaluation of the regulation loop, the load transient response is tested. The time between the application of the load transient and the turn on of the P-channel MOSFET, the output capacitor must supply all of the current required by the load. V<sub>O</sub> immediately shifts by an amount equal to ΔI<sub>(LOAD)</sub> × ESR, where ESR is the effective series resistance of C<sub>O</sub>. ΔI<sub>(LOAD)</sub> begins to charge or discharge C<sub>O</sub> generating a feedback error signal used by the regulator to return V<sub>O</sub> to its steady-state value. The results are most easily interpreted when the device operates in PWM mode. During this recovery time, V<sub>O</sub> can be monitored for settling time, overshoot or ringing that helps judge the converter's stability. Without any ringing, the loop has usually more than 45° of phase margin. Because the damping factor of the circuitry is directly related to several resistive parameters (e.g., MOSFET r<sub>DS(on)</sub>) that are temperature dependant, the loop stability analysis has to be done over the input voltage range, load current range, and temperature range.

## TPS61240, TPS61241

SLVS806B – APRIL 2009 – REVISED FEBRUARY 2012

www.ti.com

### LAYOUT CONSIDERATIONS

As for all switching power supplies, the layout is an important step in the design, especially at high peak currents and high switching frequencies. If the layout is not carefully done, the regulator could show stability problems as well as EMI problems. Therefore, use wide and short traces for the main current path and for the power ground tracks. The input and output capacitor, as well as the inductor should be placed as close as possible to the IC.

Use a common ground node for power ground and a different one for control ground to minimize the effects of ground noise. Connect these ground nodes at any place close to one of the ground pins of the IC. The feedback divider should be placed as close as possible to the control ground pin of the IC. To lay out the control ground, it is recommended to use short traces as well, separated from the power ground traces. This avoids ground shift problems, which can occur due to superimposition of power ground current and control ground current.

### LAYOUT GUIDELINES

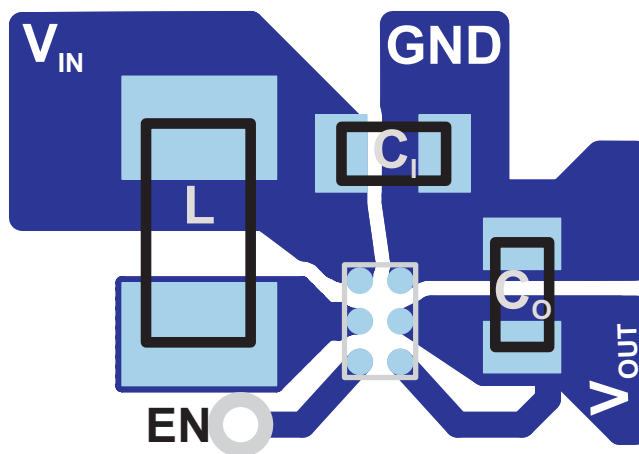

Figure 21. Suggested Layout (Top)

## THERMAL INFORMATION

Implementation of integrated circuits in low-profile and fine-pitch surface-mount packages typically requires special attention to power dissipation. Many system-dependant issues such as thermal coupling, airflow, added heat sinks, and convection surfaces, and the presence of other heat-generating components, affect the power-dissipation limits of a given component.

Three basic approaches for enhancing thermal performance are listed below:

- Improving the power dissipation capability of the PCB design
- Improving the thermal coupling of the component to the PCB
- Introducing airflow into the system

The maximum recommended junction temperature ( $T_J$ ) of the TPS6124x devices is 105°C. The thermal resistance of the 6-pin CSP package (YFF-6) is  $R_{\theta JA} = 125^\circ\text{C/W}$ . Regulator operation is specified to a maximum steady-state ambient temperature  $T_A$  of 85°C. Therefore, the maximum power dissipation is about 160 mW.

$$P_{D(\text{Max})} = [T_J(\text{max}) - T_A] / \theta_{JA} = [105^\circ\text{C} - 85^\circ\text{C}] / 125^\circ\text{C/W} = 160\text{mW}$$

## CHIP SCALE PACKAGE DIMENSIONS

The TPS6124x device is available in a 6-bump chip scale package (YFF, NanoFree™). The package dimensions are given as:

D	E
Max = 1280 $\mu\text{m}$	Max = 890 $\mu\text{m}$
Min = 1220 $\mu\text{m}$	Min = 830 $\mu\text{m}$

Chip Scale Package  
(Bottom View)

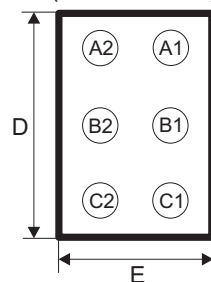

Chip Scale Package  
(Top View)

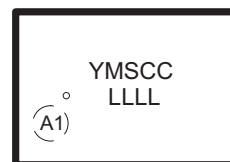

Code:

- YM - Year Month date code
- S - Assembly site code
- CC - Chip Code
- LLLL - Lot trace code

**PACKAGING INFORMATION**

Orderable Device	Status <sup>(1)</sup>	Package Type	Package Drawing	Pins	Package Qty	Eco Plan <sup>(2)</sup>	Lead/ Ball Finish	MSL Peak Temp <sup>(3)</sup>	Samples (Requires Login)
TPS61240DRVR	ACTIVE	SON	DRV	6	3000	Green (RoHS & no Sb/Br)	CU NIPDAU	Level-1-260C-UNLIM	
TPS61240DRVT	ACTIVE	SON	DRV	6	250	Green (RoHS & no Sb/Br)	CU NIPDAU	Level-1-260C-UNLIM	
TPS61240YFFR	ACTIVE	DSBGA	YFF	6	3000	Green (RoHS & no Sb/Br)	SNAGCU	Level-1-260C-UNLIM	
TPS61240YFFT	ACTIVE	DSBGA	YFF	6	250	Green (RoHS & no Sb/Br)	SNAGCU	Level-1-260C-UNLIM	
TPS61241YFFR	ACTIVE	DSBGA	YFF	6	3000	Green (RoHS & no Sb/Br)	SNAGCU	Level-1-260C-UNLIM	
TPS61241YFFT	ACTIVE	DSBGA	YFF	6	250	Green (RoHS & no Sb/Br)	SNAGCU	Level-1-260C-UNLIM	

<sup>(1)</sup> The marketing status values are defined as follows:

**ACTIVE:** Product device recommended for new designs.

**LIFEBUY:** TI has announced that the device will be discontinued, and a lifetime-buy period is in effect.

**NRND:** Not recommended for new designs. Device is in production to support existing customers, but TI does not recommend using this part in a new design.

**PREVIEW:** Device has been announced but is not in production. Samples may or may not be available.

**OBSELETE:** TI has discontinued the production of the device.

<sup>(2)</sup> Eco Plan - The planned eco-friendly classification: Pb-Free (RoHS), Pb-Free (RoHS Exempt), or Green (RoHS & no Sb/Br) - please check <http://www.ti.com/productcontent> for the latest availability information and additional product content details.

**TBD:** The Pb-Free/Green conversion plan has not been defined.

**Pb-Free (RoHS):** TI's terms "Lead-Free" or "Pb-Free" mean semiconductor products that are compatible with the current RoHS requirements for all 6 substances, including the requirement that lead not exceed 0.1% by weight in homogeneous materials. Where designed to be soldered at high temperatures, TI Pb-Free products are suitable for use in specified lead-free processes.

**Pb-Free (RoHS Exempt):** This component has a RoHS exemption for either 1) lead-based flip-chip solder bumps used between the die and package, or 2) lead-based die adhesive used between the die and leadframe. The component is otherwise considered Pb-Free (RoHS compatible) as defined above.

**Green (RoHS & no Sb/Br):** TI defines "Green" to mean Pb-Free (RoHS compatible), and free of Bromine (Br) and Antimony (Sb) based flame retardants (Br or Sb do not exceed 0.1% by weight in homogeneous material)

<sup>(3)</sup> MSL, Peak Temp. -- The Moisture Sensitivity Level rating according to the JEDEC industry standard classifications, and peak solder temperature.

**Important Information and Disclaimer:** The information provided on this page represents TI's knowledge and belief as of the date that it is provided. TI bases its knowledge and belief on information provided by third parties, and makes no representation or warranty as to the accuracy of such information. Efforts are underway to better integrate information from third parties. TI has taken and continues to take reasonable steps to provide representative and accurate information but may not have conducted destructive testing or chemical analysis on incoming materials and chemicals. TI and TI suppliers consider certain information to be proprietary, and thus CAS numbers and other limited information may not be available for release.

In no event shall TI's liability arising out of such information exceed the total purchase price of the TI part(s) at issue in this document sold by TI to Customer on an annual basis.

**OTHER QUALIFIED VERSIONS OF TPS61240 :**

- Automotive: [TPS61240-Q1](#)

NOTE: Qualified Version Definitions:

- Automotive - Q100 devices qualified for high-reliability automotive applications targeting zero defects

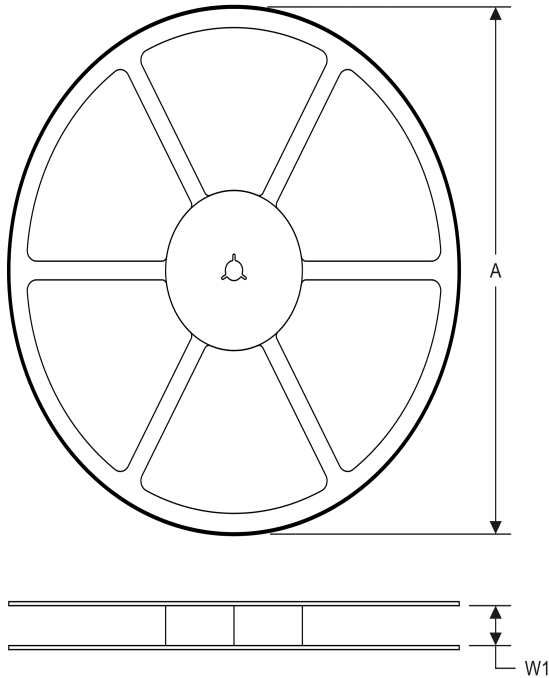
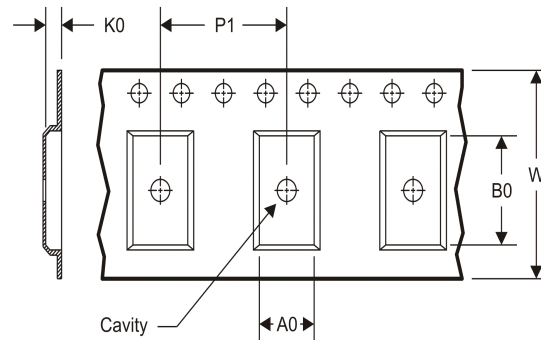
**TAPE AND REEL INFORMATION**
**REEL DIMENSIONS**

**TAPE DIMENSIONS**

A0	Dimension designed to accommodate the component width
B0	Dimension designed to accommodate the component length
K0	Dimension designed to accommodate the component thickness
W	Overall width of the carrier tape
P1	Pitch between successive cavity centers

**TAPE AND REEL INFORMATION**

\*All dimensions are nominal

Device	Package Type	Package Drawing	Pins	SPQ	Reel Diameter (mm)	Reel Width W1 (mm)	A0 (mm)	B0 (mm)	K0 (mm)	P1 (mm)	W (mm)	Pin1 Quadrant
TPS61240DRVR	SON	DRV	6	3000	179.0	8.4	2.2	2.2	1.2	4.0	8.0	Q2
TPS61240DRVT	SON	DRV	6	250	179.0	8.4	2.2	2.2	1.2	4.0	8.0	Q2
TPS61240YFFR	DSBGA	YFF	6	3000	180.0	8.4	0.98	1.41	0.69	4.0	8.0	Q1
TPS61241YFFR	DSBGA	YFF	6	3000	180.0	8.4	0.98	1.41	0.69	4.0	8.0	Q1

**TAPE AND REEL BOX DIMENSIONS**

\*All dimensions are nominal

Device	Package Type	Package Drawing	Pins	SPQ	Length (mm)	Width (mm)	Height (mm)
TPS61240DRVR	SON	DRV	6	3000	203.0	203.0	35.0
TPS61240DRVT	SON	DRV	6	250	203.0	203.0	35.0
TPS61240YFFR	DSBGA	YFF	6	3000	210.0	185.0	35.0
TPS61241YFFR	DSBGA	YFF	6	3000	210.0	185.0	35.0

DRV (S-PWSON-N6)

PLASTIC SMALL OUTLINE NO-LEAD

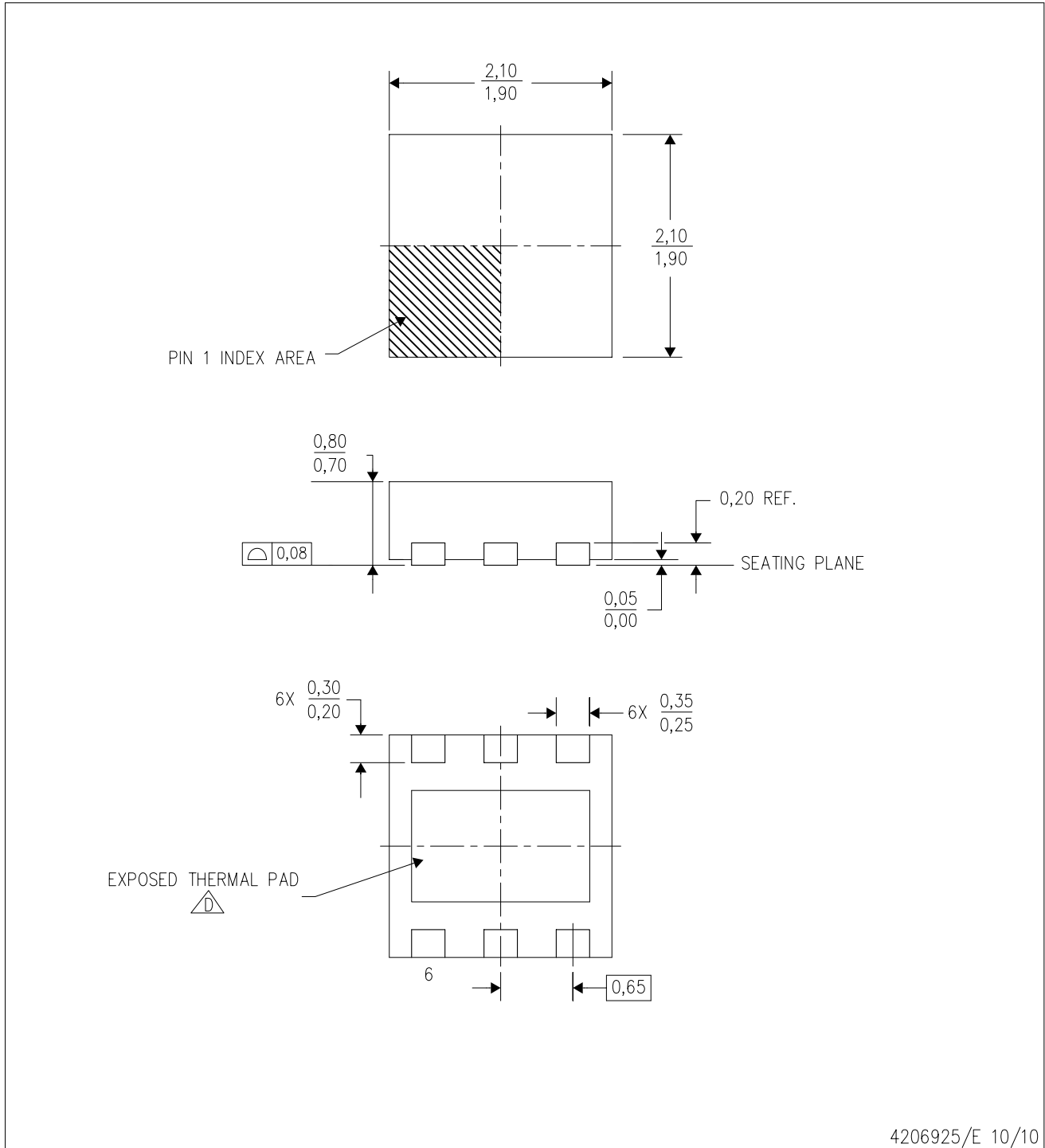

4206925/E 10/10

- NOTES:
- A. All linear dimensions are in millimeters. Dimensioning and tolerancing per ASME Y14.5M-1994.
  - B. This drawing is subject to change without notice.
  - C. Small Outline No-Lead (SON) package configuration.
  -  D. The package thermal pad must be soldered to the board for thermal and mechanical performance. See the Product Data Sheet for details regarding the exposed thermal pad dimensions.

## THERMAL PAD MECHANICAL DATA

DRV (S-PWSON-N6)

PLASTIC SMALL OUTLINE NO-LEAD

### THERMAL INFORMATION

This package incorporates an exposed thermal pad that is designed to be attached directly to an external heatsink. The thermal pad must be soldered directly to the printed circuit board (PCB). After soldering, the PCB can be used as a heatsink. In addition, through the use of thermal vias, the thermal pad can be attached directly to the appropriate copper plane shown in the electrical schematic for the device, or alternatively, can be attached to a special heatsink structure designed into the PCB. This design optimizes the heat transfer from the integrated circuit (IC).

For information on the Quad Flatpack No-Lead (QFN) package and its advantages, refer to Application Report, QFN/SON PCB Attachment, Texas Instruments Literature No. SLUA271. This document is available at [www.ti.com](http://www.ti.com).

The exposed thermal pad dimensions for this package are shown in the following illustration.

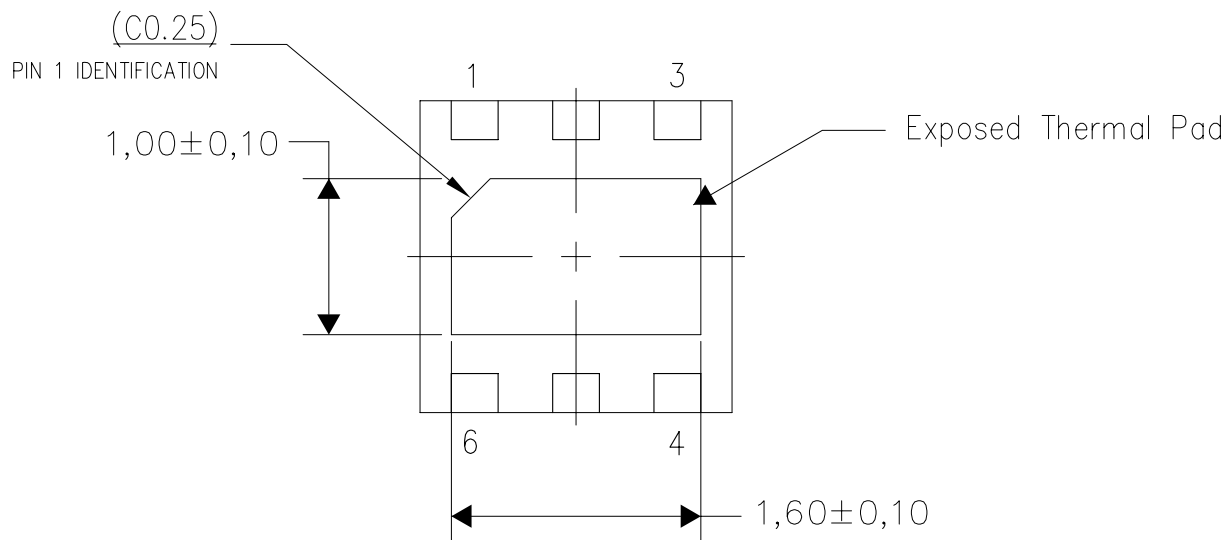

Bottom View

Exposed Thermal Pad Dimensions

4206926-3/L 11/11

NOTE: A. All linear dimensions are in millimeters

YFF (S-XBGA-N36)

DIE-SIZE BALL GRID ARRAY

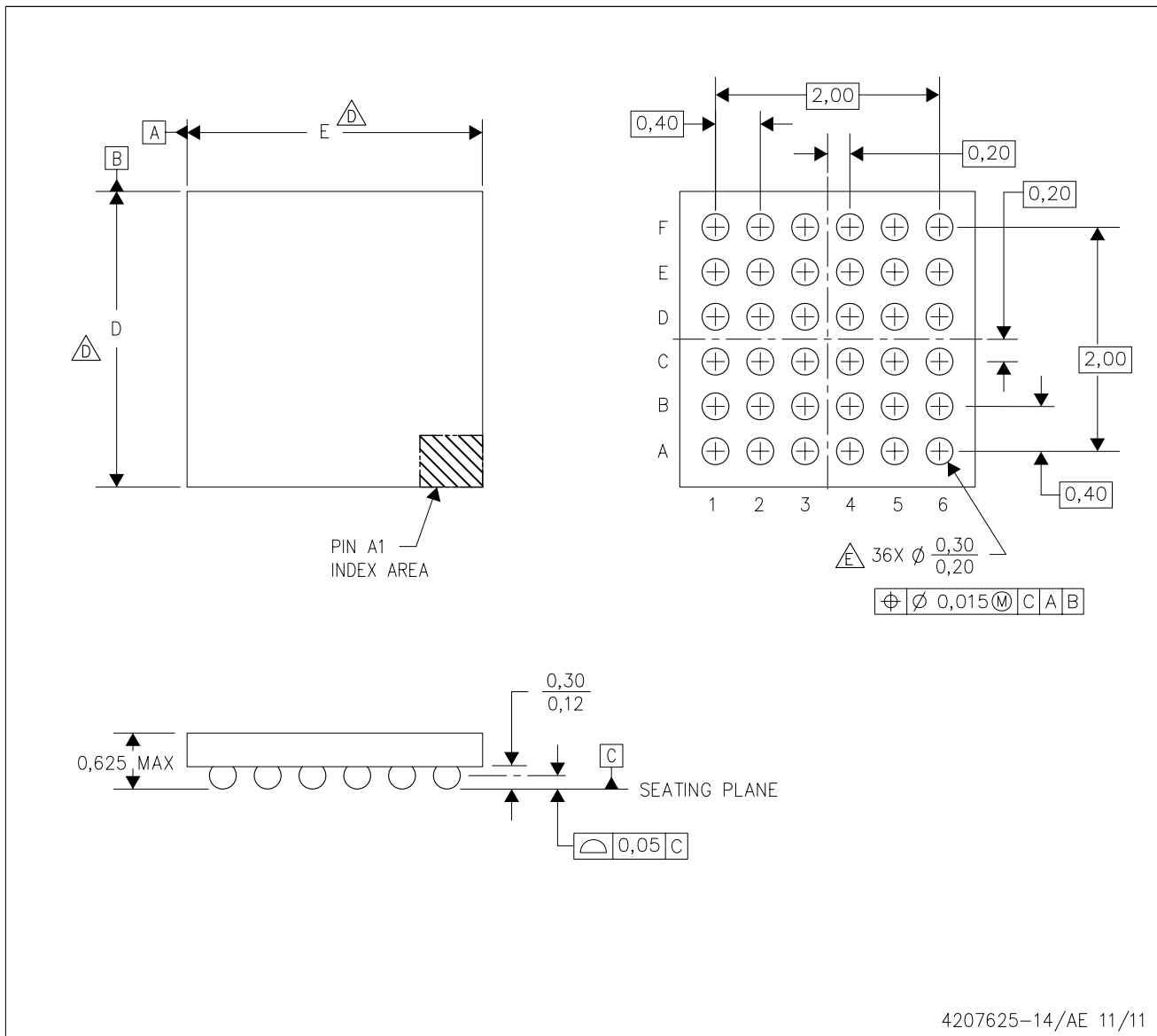

- NOTES:
- A. All linear dimensions are in millimeters. Dimensioning and tolerancing per ASME Y14.5M-1994.
  - B. This drawing is subject to change without notice.
  - C. NanoFree™ package configuration.
  - △ The package size (Dimension D and E) of a particular device is specified in the device Product Data Sheet version of this drawing, in case it cannot be found in the product data sheet please contact a local TI representative.
  - E. Reference Product Data Sheet for array population.  
6 x 6 matrix pattern is shown for illustration only.
  - F. This package contains Pb-free balls.

NanoFree is a trademark of Texas Instruments

YFF (R-XBGA-N6)

DIE-SIZE BALL GRID ARRAY

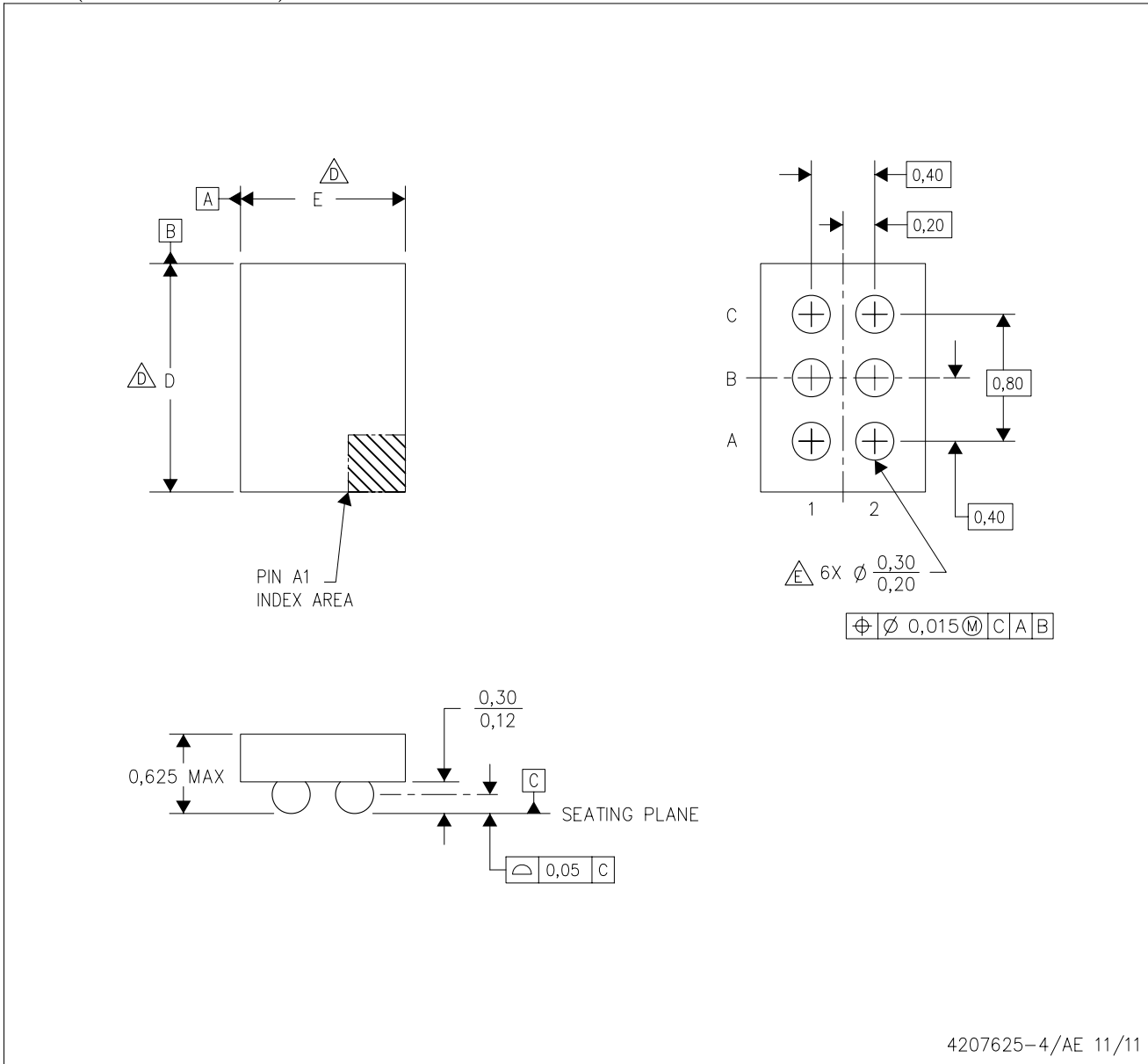

- NOTES:
- A. All linear dimensions are in millimeters. Dimensioning and tolerancing per ASME Y14.5M-1994.
  - B. This drawing is subject to change without notice.
  - C. NanoFree™ package configuration.
  - $\triangle$  The package size (Dimension D and E) of a particular device is specified in the device Product Data Sheet version of this drawing, in case it cannot be found in the product data sheet please contact a local TI representative.
  - E. Reference Product Data Sheet for array population.  
2 x 3 matrix pattern is shown for illustration only.
  - F. This package contains Pb-free balls.

NanoFree is a trademark of Texas Instruments

YFF (S-XBGA-N16)

DIE-SIZE BALL GRID ARRAY

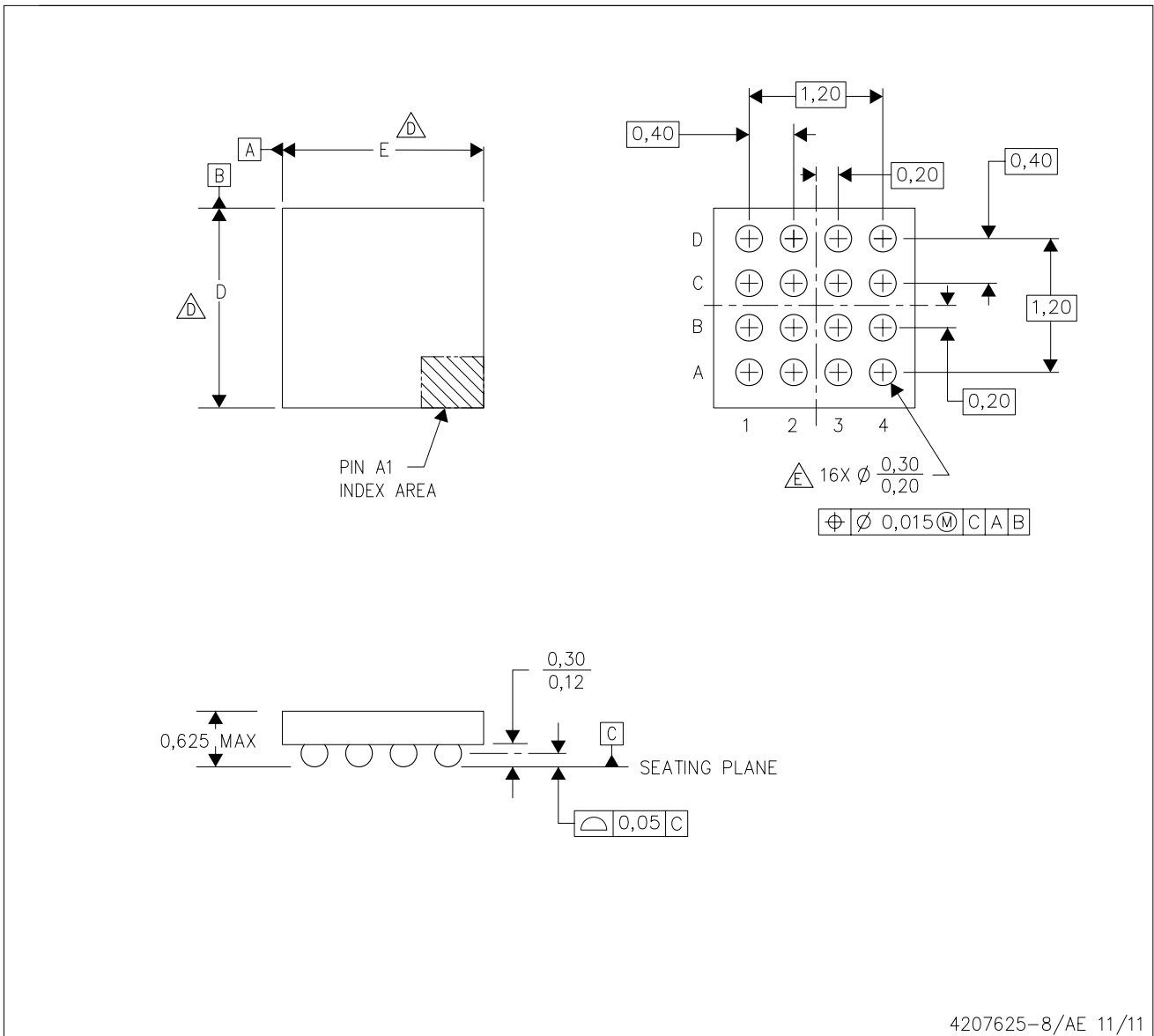

- NOTES:
- A. All linear dimensions are in millimeters. Dimensioning and tolerancing per ASME Y14.5M-1994.
  - B. This drawing is subject to change without notice.
  - C. NanoFree™ package configuration.
  - $\triangle D$  The package size (Dimension D and E) of a particular device is specified in the device Product Data Sheet version of this drawing, in case it cannot be found in the product data sheet please contact a local TI representative.
  - E. Reference Product Data Sheet for array population.  
4 x 4 matrix pattern is shown for illustration only.
  - F. This package contains Pb-free balls.

## IMPORTANT NOTICE

Texas Instruments Incorporated and its subsidiaries (TI) reserve the right to make corrections, modifications, enhancements, improvements, and other changes to its products and services at any time and to discontinue any product or service without notice. Customers should obtain the latest relevant information before placing orders and should verify that such information is current and complete. All products are sold subject to TI's terms and conditions of sale supplied at the time of order acknowledgment.

TI warrants performance of its hardware products to the specifications applicable at the time of sale in accordance with TI's standard warranty. Testing and other quality control techniques are used to the extent TI deems necessary to support this warranty. Except where mandated by government requirements, testing of all parameters of each product is not necessarily performed.

TI assumes no liability for applications assistance or customer product design. Customers are responsible for their products and applications using TI components. To minimize the risks associated with customer products and applications, customers should provide adequate design and operating safeguards.

TI does not warrant or represent that any license, either express or implied, is granted under any TI patent right, copyright, mask work right, or other TI intellectual property right relating to any combination, machine, or process in which TI products or services are used. Information published by TI regarding third-party products or services does not constitute a license from TI to use such products or services or a warranty or endorsement thereof. Use of such information may require a license from a third party under the patents or other intellectual property of the third party, or a license from TI under the patents or other intellectual property of TI.

Reproduction of TI information in TI data books or data sheets is permissible only if reproduction is without alteration and is accompanied by all associated warranties, conditions, limitations, and notices. Reproduction of this information with alteration is an unfair and deceptive business practice. TI is not responsible or liable for such altered documentation. Information of third parties may be subject to additional restrictions.

Resale of TI products or services with statements different from or beyond the parameters stated by TI for that product or service voids all express and any implied warranties for the associated TI product or service and is an unfair and deceptive business practice. TI is not responsible or liable for any such statements.

TI products are not authorized for use in safety-critical applications (such as life support) where a failure of the TI product would reasonably be expected to cause severe personal injury or death, unless officers of the parties have executed an agreement specifically governing such use. Buyers represent that they have all necessary expertise in the safety and regulatory ramifications of their applications, and acknowledge and agree that they are solely responsible for all legal, regulatory and safety-related requirements concerning their products and any use of TI products in such safety-critical applications, notwithstanding any applications-related information or support that may be provided by TI. Further, Buyers must fully indemnify TI and its representatives against any damages arising out of the use of TI products in such safety-critical applications.

TI products are neither designed nor intended for use in military/aerospace applications or environments unless the TI products are specifically designated by TI as military-grade or "enhanced plastic." Only products designated by TI as military-grade meet military specifications. Buyers acknowledge and agree that any such use of TI products which TI has not designated as military-grade is solely at the Buyer's risk, and that they are solely responsible for compliance with all legal and regulatory requirements in connection with such use.

TI products are neither designed nor intended for use in automotive applications or environments unless the specific TI products are designated by TI as compliant with ISO/TS 16949 requirements. Buyers acknowledge and agree that, if they use any non-designated products in automotive applications, TI will not be responsible for any failure to meet such requirements.

Following are URLs where you can obtain information on other Texas Instruments products and application solutions:

### Products

Audio	<a href="http://www.ti.com/audio">www.ti.com/audio</a>
Amplifiers	<a href="http://amplifier.ti.com">amplifier.ti.com</a>
Data Converters	<a href="http://dataconverter.ti.com">dataconverter.ti.com</a>
DLP® Products	<a href="http://www.dlp.com">www.dlp.com</a>
DSP	<a href="http://dsp.ti.com">dsp.ti.com</a>
Clocks and Timers	<a href="http://www.ti.com/clocks">www.ti.com/clocks</a>
Interface	<a href="http://interface.ti.com">interface.ti.com</a>
Logic	<a href="http://logic.ti.com">logic.ti.com</a>
Power Mgmt	<a href="http://power.ti.com">power.ti.com</a>
Microcontrollers	<a href="http://microcontroller.ti.com">microcontroller.ti.com</a>
RFID	<a href="http://www.ti-rfid.com">www.ti-rfid.com</a>
OMAP Mobile Processors	<a href="http://www.ti.com/omap">www.ti.com/omap</a>
Wireless Connectivity	<a href="http://www.ti.com/wirelessconnectivity">www.ti.com/wirelessconnectivity</a>

### Applications

Automotive and Transportation	<a href="http://www.ti.com/automotive">www.ti.com/automotive</a>
Communications and Telecom	<a href="http://www.ti.com/communications">www.ti.com/communications</a>
Computers and Peripherals	<a href="http://www.ti.com/computers">www.ti.com/computers</a>
Consumer Electronics	<a href="http://www.ti.com/consumer-apps">www.ti.com/consumer-apps</a>
Energy and Lighting	<a href="http://www.ti.com/energy">www.ti.com/energy</a>
Industrial	<a href="http://www.ti.com/industrial">www.ti.com/industrial</a>
Medical	<a href="http://www.ti.com/medical">www.ti.com/medical</a>
Security	<a href="http://www.ti.com/security">www.ti.com/security</a>
Space, Avionics and Defense	<a href="http://www.ti.com/space-avionics-defense">www.ti.com/space-avionics-defense</a>
Video and Imaging	<a href="http://www.ti.com/video">www.ti.com/video</a>

TI E2E Community Home Page

[e2e.ti.com](http://e2e.ti.com)

Mailing Address: Texas Instruments, Post Office Box 655303, Dallas, Texas 75265  
Copyright © 2012, Texas Instruments Incorporated